

# Abrasive dust extraction table with circumferential rim extraction



SAT/SATp

# Schuko

Dust extraction and filter technology



## Almost dust-free and clean workplace

### ■ The task

Comprehensive manual work is demanded before the completion of a good surface. The application of pickle or varnish is preceded by a visual inspection of surfaces, profiles and edges. This inspection is then followed by the “finishing touch“. This could be fine grinding on wood or intermediate grinding on varnish. In any case these works – including the cleaning of the workpiece – produce dust and are often performed in the spray room or preceding grinding shop. The workpiece supports used are more or less shaky supports. Usually, an economic workplace is not available for such important works. Very often, workpieces are prepared for further surface treatment without proper dust extraction.

### ■ The solution

A well-conceived workplace in the form of an abrasive dust extraction table: ergonomically favourable design as to height, supporting area and projection of table to allow safe and fatigue-proof working on the edges of the workpiece. Occurring dusts are collected safely and filtered extensively. This filtered air is routed back to the workroom in an energy-saving and draught-free way in a circulating air process via an additional afterfilter system.

### ■ SAT or SATp?

As to the fine-grinding of wood the series SAT with the manual cleaning of the filter bags is appropriate. If filler or pigmented lacquers we recommend the use of the series SATp including the pneumatic filter generation.



Option : Transport device



Option : Vacuum clamps



### ■ Efficient dust collection

The built-in low-noise (70 dB [A]) dust extraction becomes evenly effective on the entire table surface by a specific table profile and a circumferential extraction rim at the 2nd level, especially for the grinding of edges.

### ■ Die werkstückfreundliche Auflagefläche!

Felt-coated, very resilient and flat by ribbing, torsion-free and also suitable for the positioning of point loads (75 kg per 400 cm<sup>2</sup>).

### ■ Die Sicherheit!

Of course, all applicable regulations of safety technique and those issued by the trade supervisory boards and the employer's liability insurance for the wood industry were taken into consideration for the design of the Schuko abrasive dust extraction tables of the series SAT/SATp.

Thanks to the specific and probably at present unique design of the table surface dust is collected safely and fast, however draught-free and with hardly any noise, 70 dB (A) at a distance of 1 m. The electrical components within the extraction table like motor and cable are in explosion-proof design. The feed line with a cable being 7 m long and a 16 CEE connector with built-on motor protection switch as well as an enable/disable switch incl. phase inverter and signal lamp are not explosion-proof, for installation to a point outside the relevant ex-/ATEX zone.

### ■ Residual dust content, occupational safety

The abrasive dust extraction table contributes substantially to the decrease of the entire dust (MAK value) at the working place and therefore to the staff members' health maintenance.

### ■ Economic efficiency

The compilation of all factors described results in the amortization of an abrasive dust extraction table made by Schuko at shortest notice.



The back wall can be folded down for large workpieces.

Type	Item no.	Length A (mm)	Length B (mm)	Filter surface (m <sup>2</sup> ) filter bag (inside)	Fan (400 V) motor (kW)	Fan (400 V) air throughput (m <sup>3</sup> /h)	Weight approx. (kg)
SAT-S	532200	2.100	1.770	4,4	1,5	3.520	250
SAT-L	532300	2.710	2.370	5,6	1,5	4.320	315
SATp-S	532400	2.100	1.770	17,6	2,5	3.520	295
SATp-L	532600	2.710	2.370	21,6	2,5	4.320	360

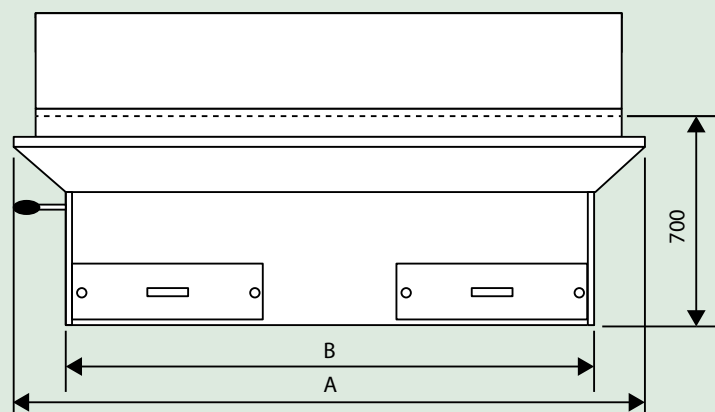
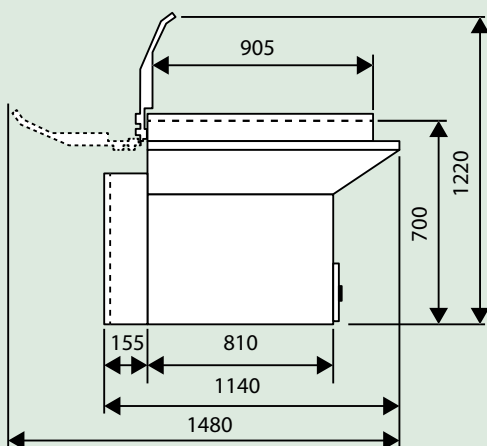

## Replacement parts

	item no.	required quantity
1 spare filter bag, inside, type K for SAT-S	533 500	4 x
1 spare filter bag, inside, type K for SAT-L	533 600	4 x
1 spare filter cartridge, inside, type PK SATp-S	533 900	8 x
1 spare filter cartridge, inside, type PL für SATp-L	533 910	8 x
1 spare filter mat, outside, for SAT/SATp, with aluminium frame and supporting grid, 406 x 565 x 20 mm		
for SAT-S	533 700	4 x
for SAT-L	533 700	5 x

## Accessories

Travelling mechanism for SAT, all types	533 400	1 x
Vacuum clamping device for work-table SAT, all types	534 600	1 x

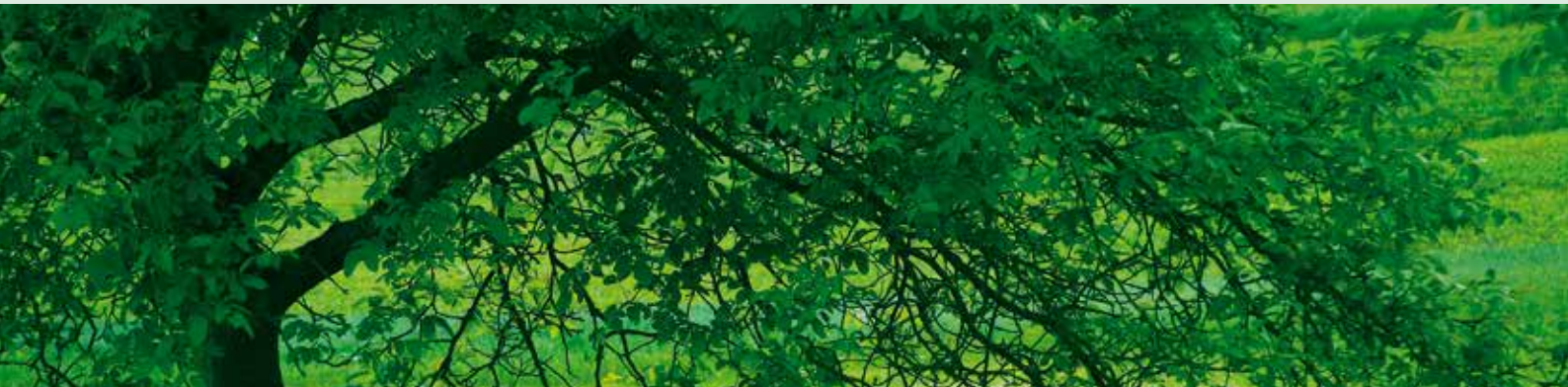

## Nature teaches us!



DE-49196 Bad Laer · Gewerbepark 2 · Tel. +49 (0) 54 24 / 8 06-0 · Fax +49 (0) 54 24 / 8 06-80 · info@schuko.de  
DE-88348 Bad Saulgau · Mackstraße 18 · Tel. +49 (0) 75 81 / 48 71-0 · Fax +49 (0) 75 81 / 48 71-81 · saulgau@schuko.de  
DE-97478 Knetzgau · Industriestraße 22 · Tel. +49 (0) 95 27 / 92 28-0 · Fax +49 (0) 95 27 / 92 28-32 · knetzgau@schuko.de  
DE-55481 Kirchberg/H. · Hugo-Wagener-Straße 11 · Tel. +49 (0) 67 63 / 303 19-0 · Fax +49 (0) 67 63 / 303 19-20 · kirchberg@schuko.de  
DE-14959 Trebbin · Gewerbegebiet Zossener Straße 4 · Tel. +49 (0) 3 37 31 / 8 67-0 · Fax +49 (0) 3 37 31 / 8 67-55 · trebbin@schuko.de  
DE-25451 Quickborn · Theodor-Storm-Straße 29 · Tel. +49 (0) 41 06 / 76 71-0 · Fax +49 (0) 41 06 / 76 71-1 · quickborn@schuko.de  
PL-62-561 Ślesin · Kolonia Sarnowa · Biskupie Sarnowskie 9 · Tel. +48 (0) 63 / 245 64 00 · Fax +48 (0) 63 / 245 61 29 · slesin@schuko.com

[www.schuko.com](http://www.schuko.com)